

## Vee Pack Sets

### Technical details

Metric

Inch

#### Operating conditions

Maximum Speed	0.5 m/sec
Temperature Range	-30°C +100°C
Maximum Pressure	700 bar

1.5 ft/sec
-22°F +212°F
10,000 p.s.i.



#### Maximum extrusion gap

Pressure bar	160	250	400	700
Maximum Gap mm	0.4	0.3	0.2	0.1
Pressure p.s.i.	2400	3750	6000	10,000

Figures show the maximum permissible gap all on one side using minimum rod  $\varnothing$  and maximum clearance  $\varnothing$ .

#### Surface roughness

	$\mu\text{mRa}$	$\mu\text{mRt}$	$\mu\text{inCLA}$	$\mu\text{inRMS}$
Dynamic Sealing Face $\varnothing d_1$	0.1 <-> 0.4	4 max	4 <-> 16	5 <-> 18
Static Sealing Face $\varnothing D_1$	1.6 max	10 max	63 max	70 max
Static Housing Faces $L_1$	3.2 max	16 max	125 max	140 max

#### Chamfers & Radii

Groove Section $\leq S$ mm	6.0	7.5	10	12.5	15.0	20.0
Min Chamfer C mm	3.0	4.0	5.0	6.5	7.5	10.0
Max Fillet Rad $r_2$ mm	0.4	0.4	1.2	1.6	1.6	1.6

#### Tolerances

$\varnothing d_1$	$\varnothing D_1$	$L_1$ mm
f9	H11	+0.2 -0

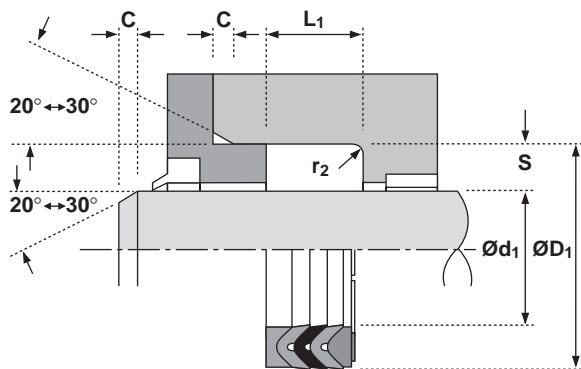

### Features

- Precision moulded Vee Rings
- Pressure distribution adaptors
- Reliable sealing

### Design

The Hallite 14 is a vee pack rod seal for heavy duty applications offering excellent performance and long life even under difficult operating conditions such as pressure surges, vibration and some misalignment. The seal consists of a male and female adaptor and three vee rings.

The male adaptor is usually manufactured from polyacetal but some of the larger sizes use rubberised fabric. It has grooves across one face to ensure equal pressure to the sealing edges of the vee ring.

All sizes have vee rings manufactured from rubberised fabric because this has strength and durability and permits an oil film to lubricate the other parts of the seal. The smaller sizes are supplied with a rubber vee ring between the rubberised fabric vee rings. The number and type of vee rings used are :

	Up to 139 mm $\varnothing$	Above 139mm $\varnothing$
Rubberised fabric vee rings	2	3
Rubber vee rings	1	

The female adaptor uses a hard rubberised fabric to support the vee rings and protect them from extrusion damage. At high pressures the lips of the adaptor act as a secondary seal.

# 14

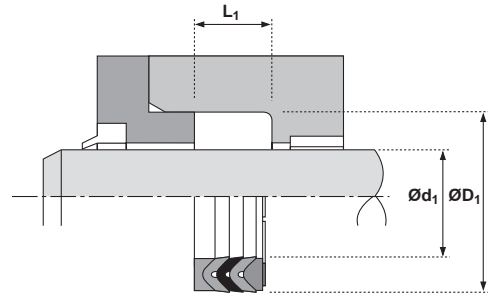

$\varnothing d_1$	TOL f9	$\varnothing D_1$	TOL H11	$L_1$ +0.2-0	PART No.
20	-0.020 -0.072	32	+0.16 +0.00	16.50	4204930
25	-0.020 -0.072	40	+0.16 +0.00	16.50	4205030
30	-0.020 -0.072	45	+0.16 +0.00	16.50	4205130
35	-0.025 -0.087	50	+0.16 +0.00	16.50	4205230
40	-0.025 -0.087	55	+0.19 +0.00	16.50	4205330
45	-0.025 -0.087	65	+0.19 +0.00	20.50	4205430
50	-0.025 -0.087	70	+0.19 +0.00	22.00	4205530
55	-0.030 -0.104	75	+0.19 +0.00	22.00	4205630
60	-0.030 -0.104	80	+0.19 +0.00	27.00	4205730
65	-0.030 -0.104	85	+0.22 +0.00	30.00	4205830
70	-0.030 -0.104	90	+0.22 +0.00	30.00	4205930
75	-0.030 -0.104	95	+0.22 +0.00	30.00	4206030
80	-0.030 -0.104	100	+0.22 +0.00	30.00	4206130
90	-0.036 -0.123	110	+0.22 +0.00	30.00	4206230
100	-0.036 -0.123	120	+0.22 +0.00	30.00	4199130

$\varnothing d_1$	TOL f9	$\varnothing D_1$	TOL H11	$L_1$ +0.2-0	PART No.
110	-0.036 -0.123	130	+0.25 +0.00	30.00	4206330
115	-0.036 -0.123	140	+0.25 +0.00	34.00	4206430
125	-0.043 -0.143	150	+0.25 +0.00	34.00	4206530
140	-0.043 -0.143	165	+0.25 +0.00	34.00	4206630
150	-0.043 -0.143	180	+0.25 +0.00	45.00	4206730
160	-0.043 -0.143	190	+0.29 +0.00	45.00	4206830
180	-0.043 -0.143	210	+0.29 +0.00	45.00	4206930
195	-0.050 -0.165	225	+0.29 +0.00	47.50	6582130
200	-0.050 -0.165	230	+0.29 +0.00	45.00	4207030
220	-0.050 -0.165	250	+0.29 +0.00	47.50	6582330
245	-0.050 -0.165	275	+0.32 +0.00	47.50	6582430
270	-0.056 -0.186	300	+0.32 +0.00	47.50	6582530
290	-0.056 -0.186	320	+0.36 +0.00	49.00	6582630
320	-0.062 -0.212	360	+0.36 +0.00	58.00	6582730
380	-0.062 -0.212	420	+0.40 +0.00	60.00	6584030